

We're getting 5 boards made anyway, so we're going to go with an 8-port solution. One RJ21, but either gender. You will string 3 boards together for the lines, and one board for the trunk. Each board muxes 8 T&Rs into one output. The first board will have an RJ21 and 4 x RJ45s to feed the other two boards. The 2nd and 3rd board will have 2 x RJ45s for lines 9-16 and 17-24. All four boards will have chained '595 shift registers for control. This will not be a terribly general purpose board; the leftover board #5 might get used as a general purpose RJ21 breakout. Control is done by a separate board (really just clock, data, and output enable).

J1 telecom	
R1 1	25 T1
R2 2	27 T2
R3 3	28 T3
R4 4	29 T4
R5 5	30 T5
R6 6	31 T6
R7 7	32 T7
R8 8	33 T8
R9 9	34 T9
R10 10	35 T10
R11 11	36 T11
R12 12	37 T12
R13 13	38 T13
R14 14	39 T14
R15 15	40 T15
R16 16	41 T16
R17 17	42 T17
R18 18	43 T18
R19 19	44 T19
R20 20	45 T20
R21 21	46 T21
R22 22	47 T22
R23 23	48 T23
R24 24	49 T24
R25 25	50

The male and female versions of the RJ-21 are opposite pinouts of each other. Linecards provide a female connector, which means that the male end requires 24 pairs. Trunk cards provide a male connector, which means the female end uses only the first 8 pairs (which show up as the last 8 on this connector).

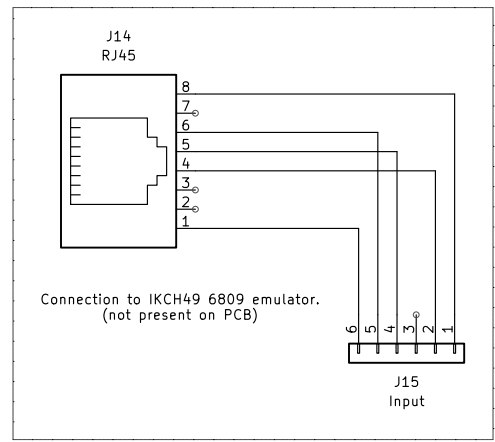

2025-06-11
Consider yourself lucky! There is "nothing" connected on 9/34 on the trunk card (which is what 17/42 maps to with the inverse connector), and nothing connected on 25/50 on the line card.
The hack of just connecting those together worked.
Future rev should decouple the pins (via solder jumper) from the RJ-21.
2025-06-17
Well, not so lucky. The external grounds are connected on the trunk where the J2/J3 needs to tap off from, so we ended up cutting the traces from J2/J3 to J1. Not the end of the world, but more work.
Also, it would be nice to have solder jumpers for not only disconnecting, as above, but also connecting J2/J3 and the equivalent positions on J6/J7.
2025-06-18
Turns out I did need snubber diodes. The voltage was spiking to over 35V on the resistor/LED junction!
Also, added 47uF capacitors on each board, but that doesn't help with the +5V ringing, which seems to be around 20MHz if I've done the measurement correctly.